

**KENT**

*UF Membrane*

*Water Purifiers*

HOUSE of PURITY

## Instruction Handbook for Installation, Operation and Maintenance.

# KENT GEM

RO Water Purifier



### **KENT TECHNOLOGY**

Double purification, removes dissolved impurities and maintains minerals.

**RO + UF + TDS Control**

Mineral RO™ © 2005 - 2012 KENT RO SYSTEMS LTD, the process & purifier is patented vide patent no. 199716.

KENT GEM's design is registered vide registration no. 262261

# Welcome TO KENT

Dear Customer,

Welcome to the world of KENT, leaders of water purification industry in India. With a KENT product you have all reasons to smile, since at KENT we take pride in the quality and laboratory-tested performance of our products.

We are confident that your decision to own KENT GEM Mineral RO™ WATER PURIFIER will go a long way in serving you with pure and mineral enriched drinking water – thus keeping you and your family in good health. We assure you, that you will be satisfied with its trouble-free performance and quality, which comes without any compromise.

This manual is an effort towards familiarizing you with the operation and maintenance of KENT GEM Mineral RO™ WATER PURIFIER. Before operating the unit, please read it thoroughly and retain it for future reference. To ensure that the warranty of your water purifier is effective, fill up the enclosed warranty card and send the installation report within 15 days of purchase. Should you need further assistance, do not hesitate to contact your nearest KENT dealer or branch.

Best wishes,

KENT RO SYSTEMS LTD.

## Contents

1.	KENT TECHNOLOGY -	
	A Breakthrough in Water Purification	1
2.	Salient Features of KENT GEM Mineral RO™ WATER PURIFIER	1
4.	Important Instructions	2
5.	Reverse Osmosis Process	3
6.	UF Process	3
7.	Water Flow Diagram	4
8.	Electrical Circuit Diagram	4
9.	Automatic Operation	5
10.	Installation Instructions	5
11.	TDS Adjustment	7
12.	Starting Up the Purifier	7
13.	Recommended Usage of Reject Water	7
14.	Maintenance	8
15.	Technical Specifications	8

# KENT TECHNOLOGY

## A Breakthrough in Water Purification\*

Kent proudly presents KENT GEM Mineral RO™ WATER PURIFIER - its new and advanced domestic water purifier which provides 100% pure & healthy drinking water.

The futuristic KENT GEM Mineral RO™ WATER PURIFIER, developed at KENT laboratory broadly comprises of state-of-the-art RO+UF+TDS Control System. The initial purification by RO membrane having porosity as fine as .0001 microns completely removes even the dissolved impurities (hard salts, heavy metals etc.). Double purification by UF membrane gives additional protection from deadly harmful micro-organisms. Moreover, the patented TDS Control System intelligently retains essential natural minerals in purified water thus, taking total care of your health and wellbeing

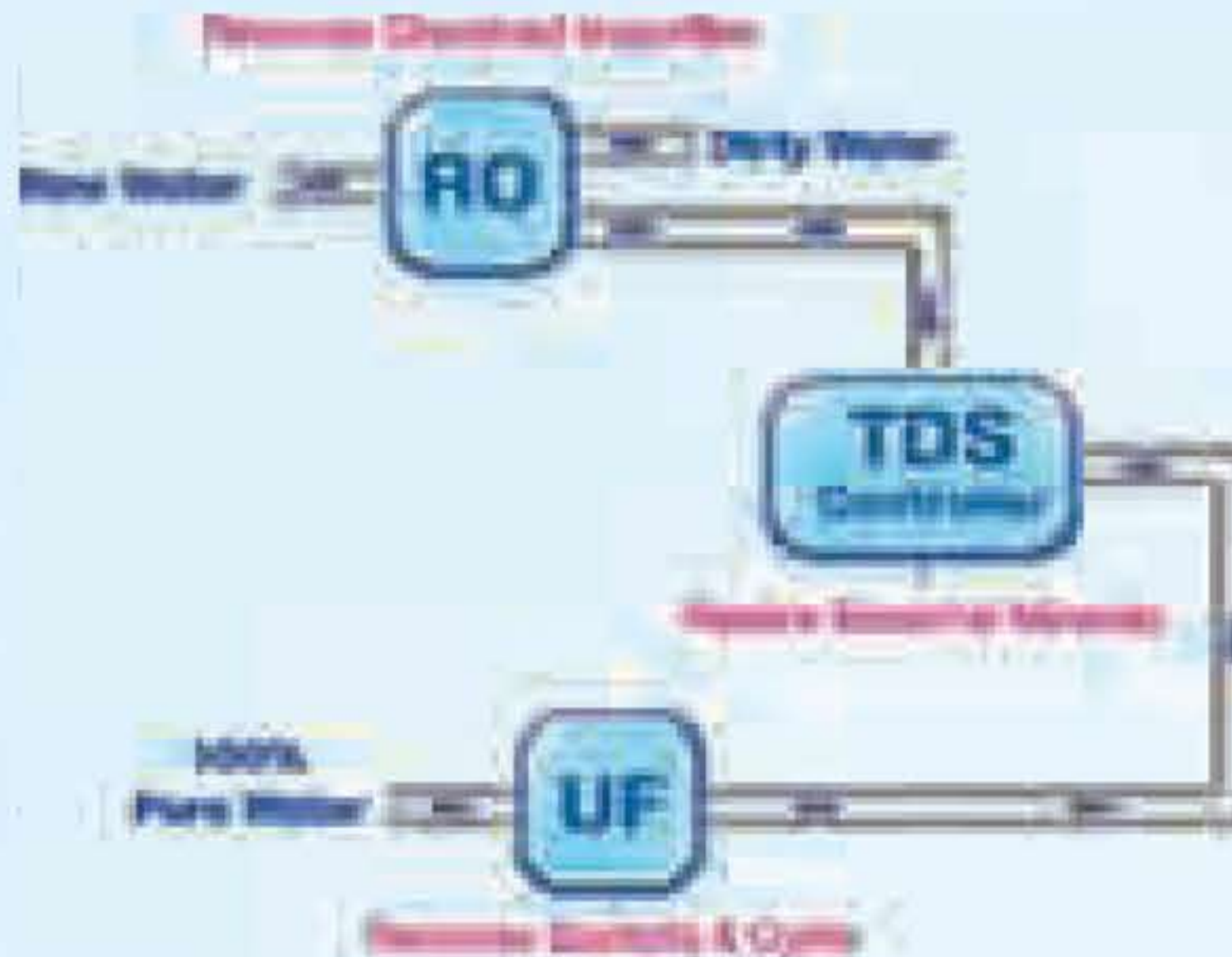

### Salient Features of KENT GEM Mineral RO™ WATER PURIFIER

- Compact and modern counter Top design- best suited for domestic purpose
- Compatible to connect with refrigerator
- Counter top / Under the Counter design with tap or Faucet water dispensing option available
- Double purification by RO+ UF process
- Based on mineral RO technology which allows to control the contents of natural minerals in RO purified water using the innovative TDS controller
- Adjustable TDS Control System allows adjustment of TDS level of purified water
- 5 litres inbuilt storage tank that makes purified water available on demand
- RO and UF Membranes fused inside membrane housing to prevent tampering
- Push-fit components for leak-proof and maintenance-free performance
- Fully automatic operation with auto-on and auto-off function
- ABS construction for corrosion-free life span
- Equally suitable for water from all sources

### Items in the Box

1. KENT GEM Mineral RO™ WATER PURIFIER	1 no.
2. 3-Way Connector	1 no.
3. S.S. Ball Valve	1 no.
4. Faucet	1 no.
5. Food Grade Pipe (White & Blue)	3 meters each
6. Instruction Manual	1 no.

# Important Instructions



Avoid exposure to direct sunlight and installation in damp areas.

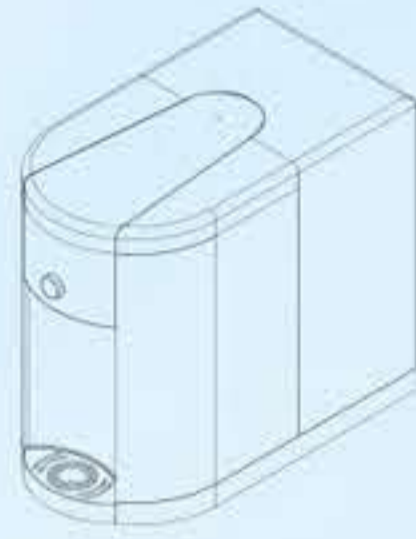

Make sure that the temperature of water entering the purifier is within 10-35° C.

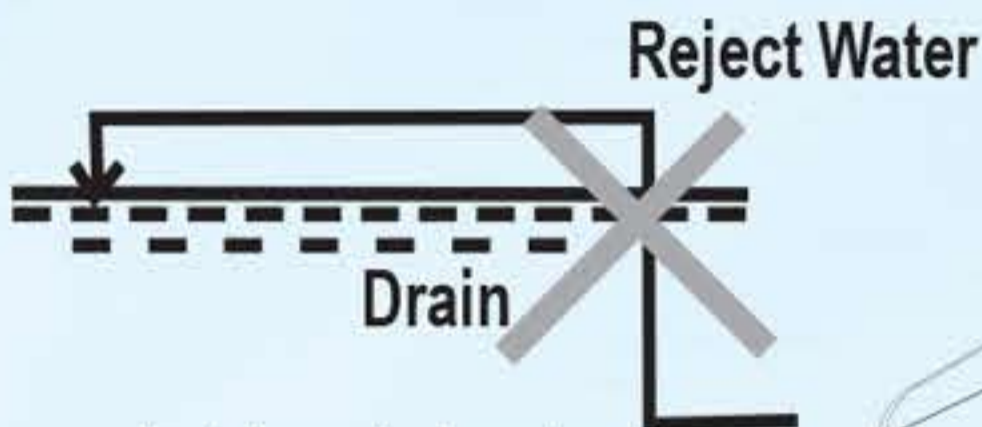
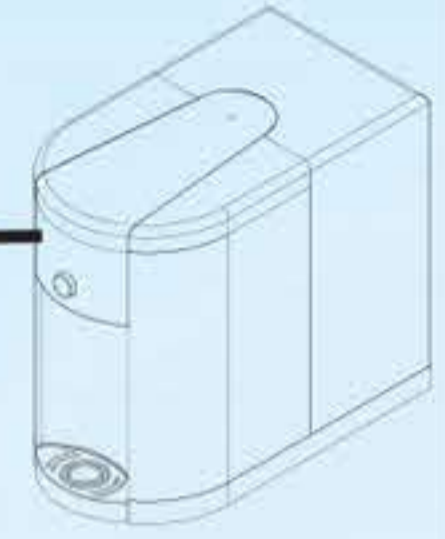

Make sure that the reject water pipe is not placed at a level higher than the system, otherwise reject water may flow backwards into the purifier.

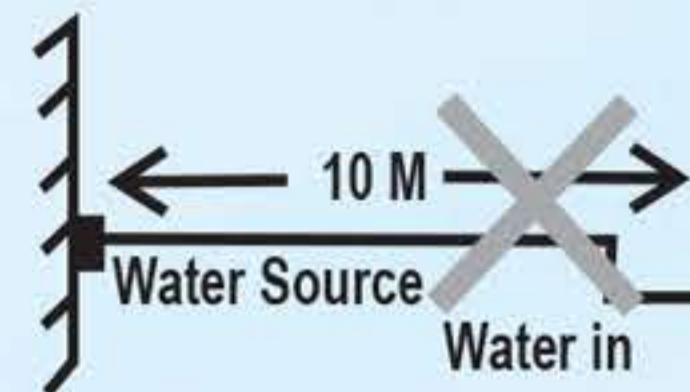
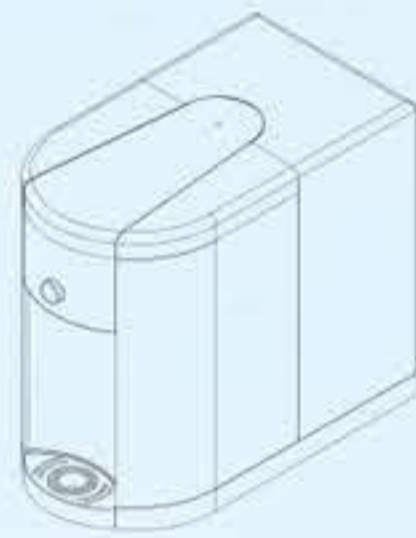

Maximum distance between the water source and the purifier should not be more than 3 meters.

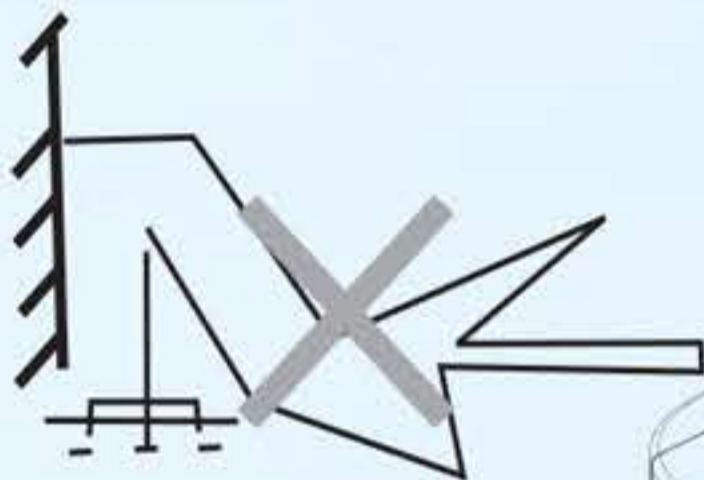
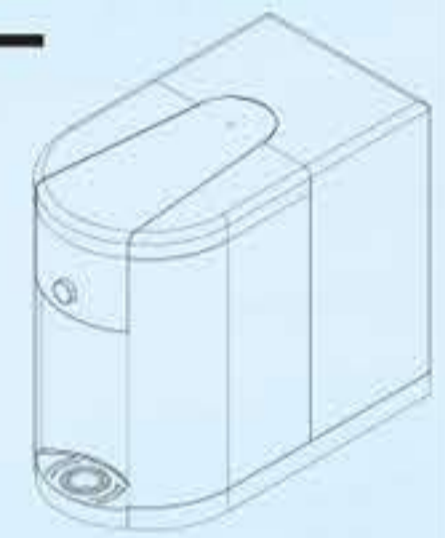

Avoid sharp bends in the pipe fittings. Do not bend or block the reject water pipe.

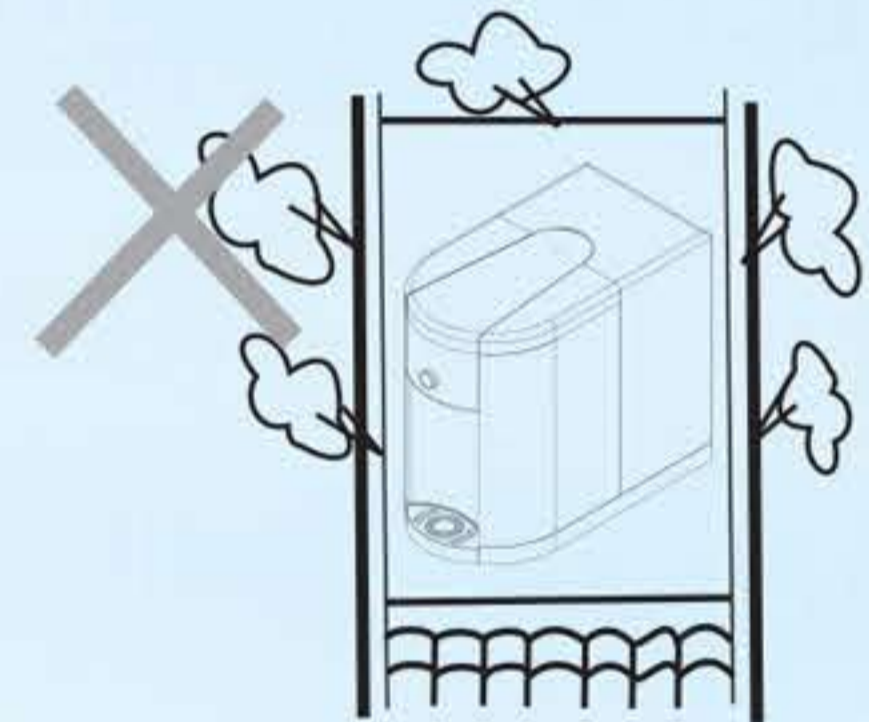
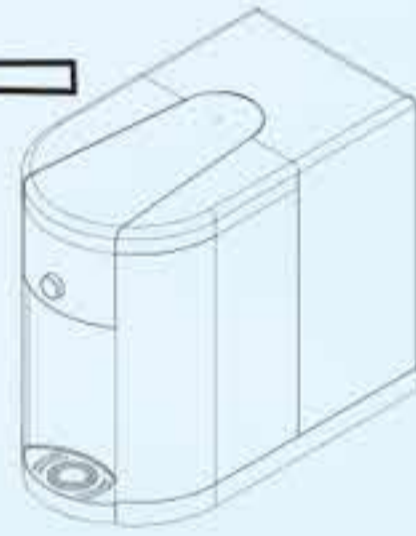

Do not confine the purifier in a cabinet.



In case of not using the purifier for more than two days, kindly switch off the power supply and drain the storage tank.

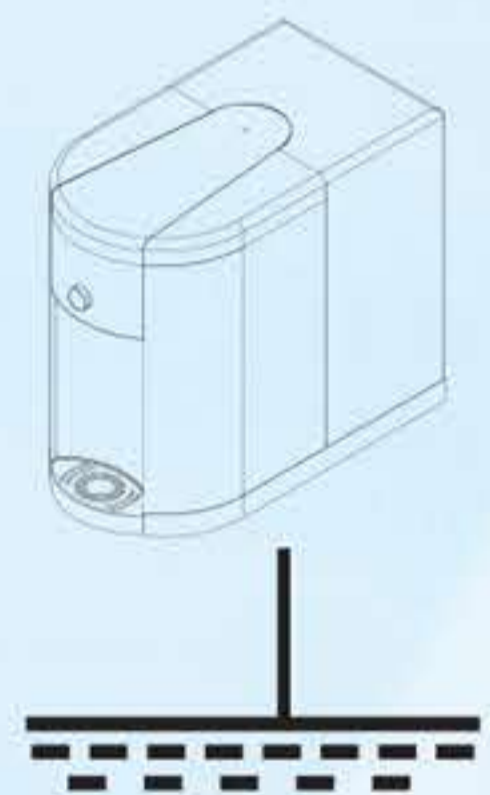

To keep the storage tank clean, it should be drained once in 15 days.



Always use genuine Kent spares for optimum performance

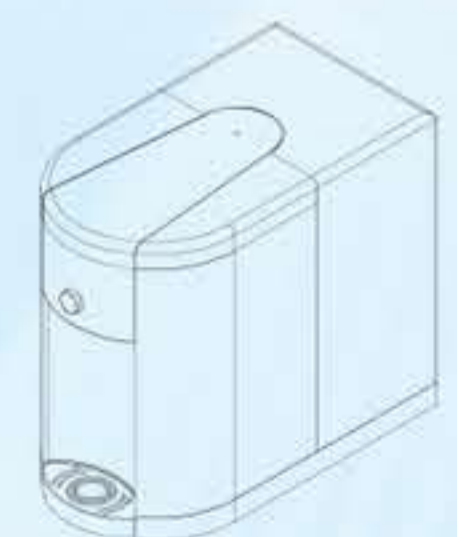

Do not try to service the purifier on your own. Instead, call service technician for help.

## Reverse Osmosis Process

The Reverse Osmosis process, also known as hyper filtration, is the finest filtration process known till date. The process ensures the removal of particles as small as ions from a solution. Reverse Osmosis uses a semi-permeable membrane to remove salts from potable / brackish water. In Reverse Osmosis, water pressure applied to the concentrated side forces the process of osmosis into reverse. Under enough pressure, pure water is "squeezed" through the membrane from the concentrated side to the diluted side. Salts dissolved in water as charged ions are repelled by the RO membrane. The rejected impurities on the concentrated side of the membrane are washed away in a stream of waste water and thus not get accumulated as on a traditional filter.

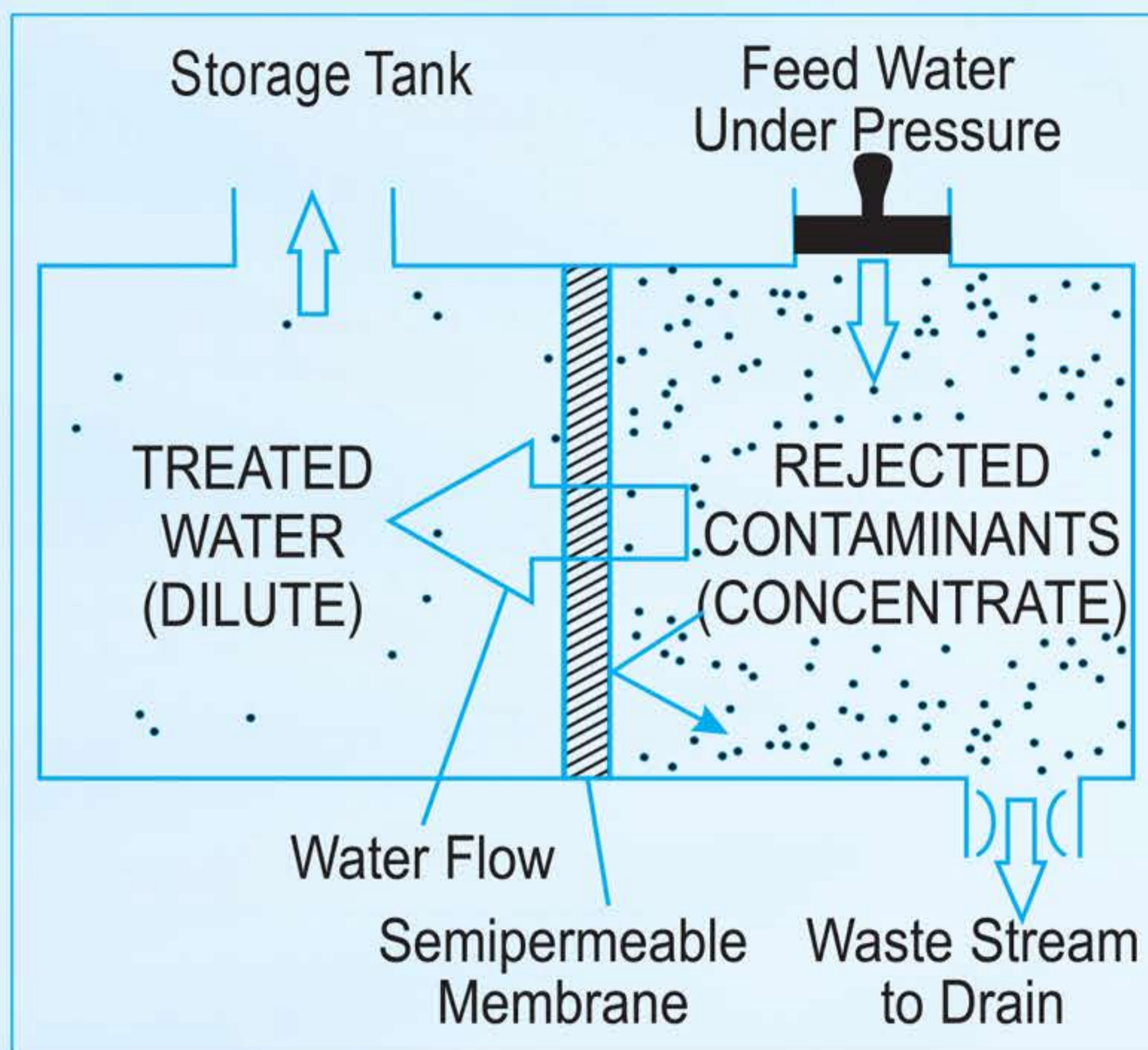

## UF Process

Ultra Filtration is a separation process that uses membranes with pore sizes in the range of 0.1 to 0.01 micron. UF membranes remove high molecular-weight substances, colloidal materials, and organic and inorganic polymeric molecules including bacteria and viruses. Low applied pressures are therefore sufficient to achieve high flux rates from an Ultra Filtration membrane.

# Water Flow Diagram

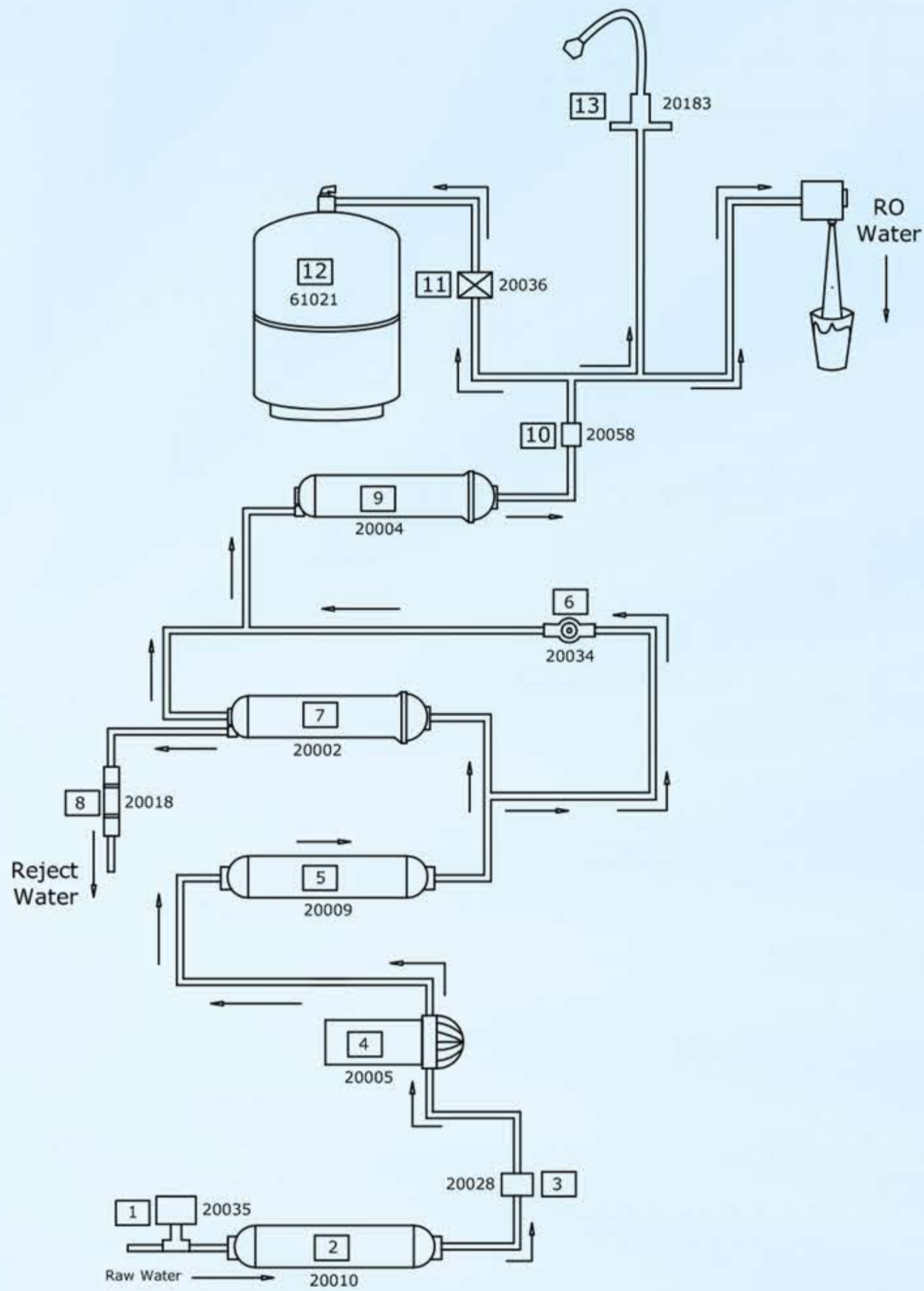

S.NO.	SPARE PART CODE	ITEM DESCRIPTION
1	20035	LOW PRESSURE SWITCH
2	20010	SEDIMENT FILTER
3	20028	SOLENOID VALVE
4	20005	BOOSTER PUMP
5	20009	ACTIVATED CARBON FILTER
6	20034	TDS CONTROL VALVE
7	20002	RO MEMBRANE
8	20018	FLOW RESTRICTOR TUBE
9	20004	UF MEMBRANE
10	20058	NON RETURN VALVE
11	20036	HIGH PRESSURE SWITCH
12	61021	HYDROSTATIC TANK
13	20183	FAUCET

# Electrical Circuit Diagram

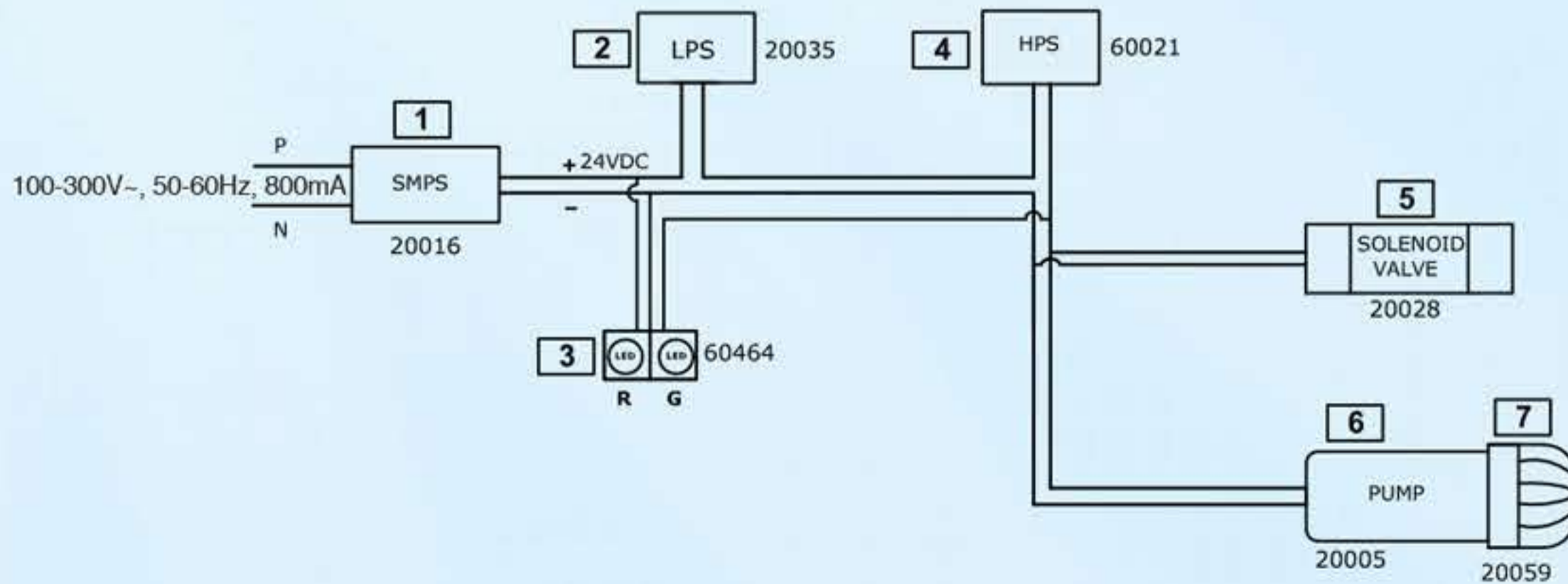

S.NO.	SPARE PART CODE	ITEM DESCRIPTION
1	20016	SMPS
2	20035	LOW PRESSURE SWITCH (LPS)
3	60464	LED
4	60021	HIGH PRESSURE SWITCH (HPS)
5	20028	SOLENOID VALVE
6	20005	BOOSTER PUMP
7	20059	PUMP HEAD

# Installation Report

Product : **KENTGEM Mineral RO™ Water Purifier**

Serial No.

Customer's Name \_\_\_\_\_

Customer's Address \_\_\_\_\_  
\_\_\_\_\_  
\_\_\_\_\_

Customer's Ph. \_\_\_\_\_

TDS of Purified Water \_\_\_\_\_

Customer's Signature \_\_\_\_\_

Invoice No. \_\_\_\_\_

Invoice Date \_\_\_\_\_

Installation Date \_\_\_\_\_

Service Provider's Name: \_\_\_\_\_

Service Provider's Address \_\_\_\_\_  
\_\_\_\_\_  
\_\_\_\_\_

Service Provider's Ph. \_\_\_\_\_

TDS of Raw Water \_\_\_\_\_

Service Provider's Stamp \_\_\_\_\_

By signing on this installation report, the customer hereby agrees to the terms & conditions of warranty mentioned on the back side of the warranty card.



## Automatic Operation

- The purifier automatically shuts off when the storage tank becomes full.
- The purifier does not start when inlet water supply pressure is below 0.3 kg/cm<sup>2</sup>.
- The purifier automatically restarts when water level drops below the maximum.
- The purifier does not allow any water rejection in absence of electricity / when tank is full.

## Installation Instructions

KENT GEM WATER PURIFIER is a product of advanced technology, which ensures safe and clean drinking water. The purifier is easy and convenient to install.

### Recommended Site Preparations:

- 100-300V~, 50-60Hz single phase AC supply not more than 3m away from the point of installation
- Raw water supply with ½" nipple not more than 3m away
- Drain for reject water not more than 3m away
- For optimum inlet pressure, source water tank should be at least 10ft above the purifier installed
- Install the purifier near a sink for easy availability of inlet and reject water lines

### Installation Procedure :

1. Fasten the SS ball valve to the ¼ inch port of the 3-way connector.

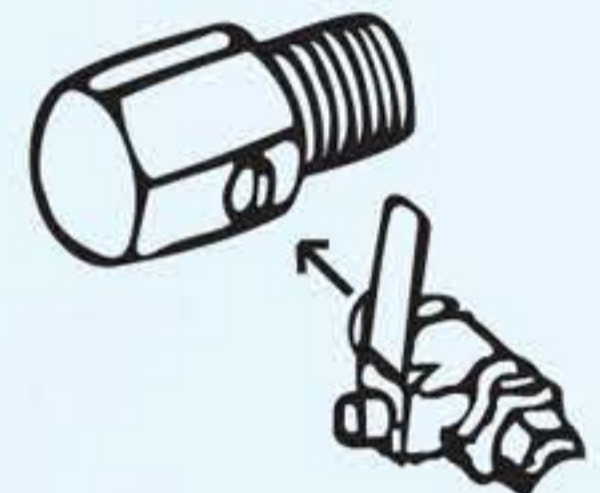

2. Attach threaded end of 3-way connector to raw water supply and plug-off the other end or connect to a tap.

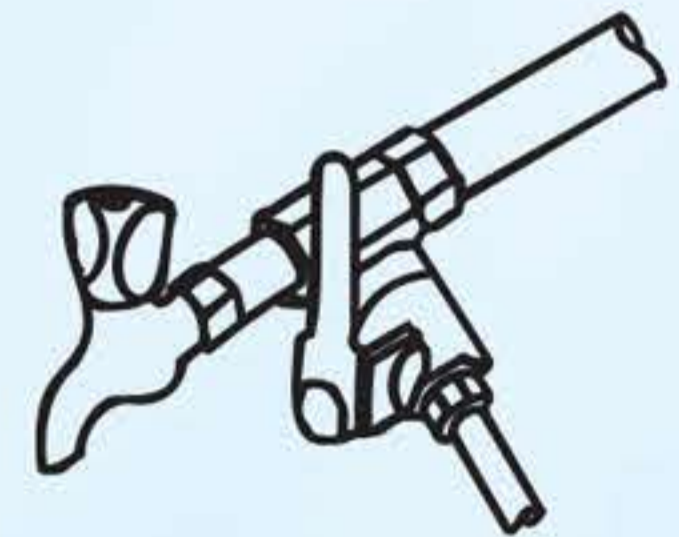

3. Now connect one end of white pipe to SS ball valve and other end to elbow fitting connector labeled as Raw Water, on the back side of purifier.

 Use white pipe for raw water supply

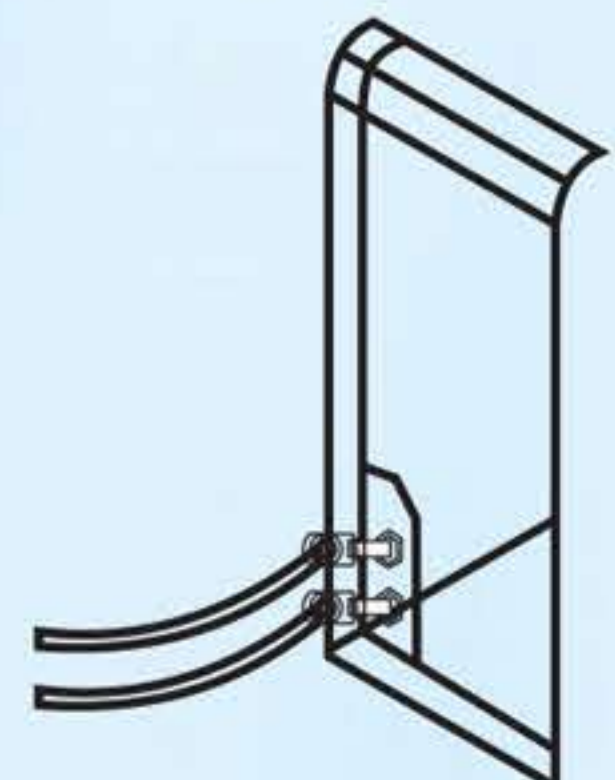

4. Connect one end of blue pipe to elbow fitting connector labeled as REJECT WATER and lead the other end to drain.
5. Turn on the lever given on SS ball valve to initiate the water flow to the purifier.

 Use blue pipe for reject water

6. Allow the filters to pre-soak in water for 2-3 minutes.
7. Connect the power supply.
8. Installation is complete.

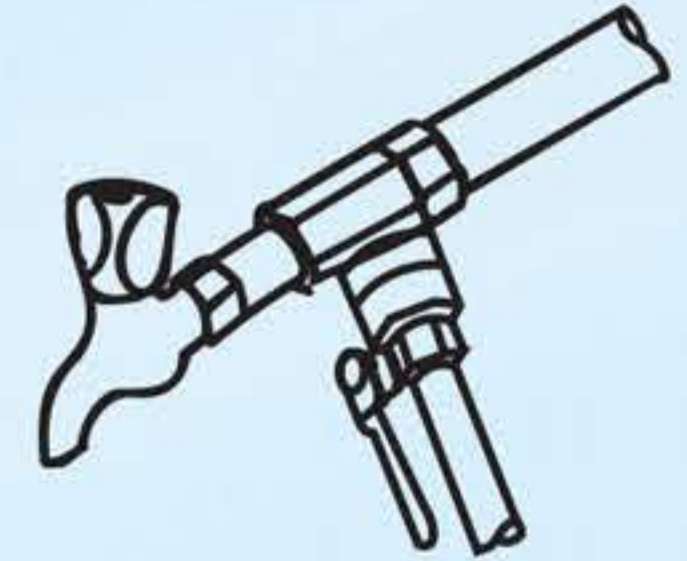

- Note:
- In case, you choose to place water purifier under the counter, install the faucet on the kitchen sink or slab, connect one end of the white pipe to the faucet and the other end to the fitting connector labeled as 'Faucet' on the back side of the purifier
  - If the water purifier is placed as 'Table Top', never remove the dead plug from the connector labeled as faucet

## TDS Adjustment

The unique TDS Control System enables customers to retain the contents of natural minerals (TDS) in purified water, as per their requirement.

- To increase the TDS level, turn screw of the valve anticlockwise; resulting into increase in mineral content
- To decrease the TDS level, turn screw of the valve clockwise; resulting into decrease in mineral contents.

 We recommend keeping the TDS at lowest but not below 50mg/l.

## Starting Up the Purifier

- Switch on the power supply
- Allow the storage tank to fill to the maximum level
- Switch off the power supply
- Open the Tap or Faucet present at the Purifier and drain the tank as to
- remove residual dust particles present in the pipes and storage tank
- Switch on the power supply
- Purifier is ready to use

- NOTE:**
- The glowing red LED indicates that the power is on
  - The glowing green LED indicates that the purification process is on

## Maintenance

To ensure that the purifier operates at its BEST, a routine maintenance must be performed. The frequency of the maintenance will greatly depend upon the raw water quality and consumption of purified water.

- Storage tank must be drained once in 2 weeks. Open the tap or faucet present at the Purifier and drain the tank and switch on the power supply.
- Replace sediment filter and activated carbon filter once in 12 months. It is recommended to change FRT along with the filters.
- Replace RO membrane once in 2 years.
- Replace UF membrane once in 2 years.
- In the event of not using purifier for a long time (while going for a holiday, tour etc.), make sure that you disconnect the power supply, turn off the raw water supply and drain the storage tank.



**Please note that the replacement time of consumables such as filters and membrane is dependant on the quality of raw water and the quantity of purified water consumed.**



**Use genuine Kent spares for optimum performance.**

The reverse osmosis system contains a replaceable treatment component critical for the effective reduction of total dissolved solids and that product water is tested periodically to verify that the system is performing properly.

Replacement of spare parts are as under:-

-20010	SP Inline Sediment Filter 8"
-20009	SP Inline Carbon Block Filter 8"
-20002	SP RO Membrane Welded 8" Housing
-20004	SP UF Membrane Welded 8" Housing
-20018	SP FRT 550

**Note: Filters and membrane are consumables. Their replacement time is dependent on the quality of raw water and water consumption. They are not covered under the warranty. However, if a filter chokes within six months and a membrane within a year, it will be cleaned/ repaired/ replaced free of cost. Changing the filters and system inspection is available on call. The treatment capacity of RO membrane will reduce with time due to clogging of pores of membranes.**

**"This reverse osmosis system contains a replaceable component critical to the efficiency of the system. Replacement of the reverse osmosis component should be with one of identical specifications as defined by the manufacturer, to ensure the same efficiency and contaminant reduction performance."**

## Technical Specifications

Product	:	KENT GEM Mineral RO™ WATER PURIFIER
Product Code	:	11029
Applications	:	Suitable for Purification of Brackish/Tap Water
Purification Capacity	:	Upto 15 LPH*
Body Material	:	ABS Engineering Plastic
Mounting	:	Counter Top / Under the Counter
Dimensions(mm)	:	440 (L) x 250 (W) x 400 (H)
Inlet Water Pressure/Temp (Min.)	:	0.3 kg/cm <sup>2</sup> or 4.267psi/10°C
Inlet Water Pressure/Temp (Max.)	:	3.0 kg/cm <sup>2</sup> or 42.67psi/35°C
Filter Cartridge	:	Sediment, Activated carbon
UF Filter	:	Ultra Filtration Membrane
Weight	:	11.500 kg
Storage Capacity	:	5 Litre
Membrane Type	:	Thin Film Composite RO
Max. Duty Cycle	:	75L/day
Booster Pump Voltage	:	24V DC
Power Consumption	:	60W
Mains Voltage	:	100-300V ~ ,50-60Hz 800mA 



HOUSE of PURITY



ISO 9001:2008  
Certified



**For customer complaints, contact customer care officer at:**

E-6, 7 & 8, Sector-59, Noida, UP-201 309, India

Call: 09582-123456 or Fixed line: +91-120-4669666

E-mail: [service@kent.co.in](mailto:service@kent.co.in)

**Manufactured by:**

**KENT RO SYSTEMS LTD.**

Khasra No. 93, Village-Bantakhedi, Tehsil-Roorkee,  
District-Haridwar, Uttarakhand-247 668, India

**Marketed by:**

**KENT RO SYSTEMS LTD.**

E-6, 7 & 8, Sector-59, Noida, U.P.-201 309, India

Ph.: +91-120-3075075

E-mail: [sales@kent.co.in](mailto:sales@kent.co.in) Website: [www.kent.co.in](http://www.kent.co.in)



Innovations for  
Better Living